



**FFC**

BY PALADIN

# OPERATOR'S AND PARTS MANUAL

## POWER RAKE

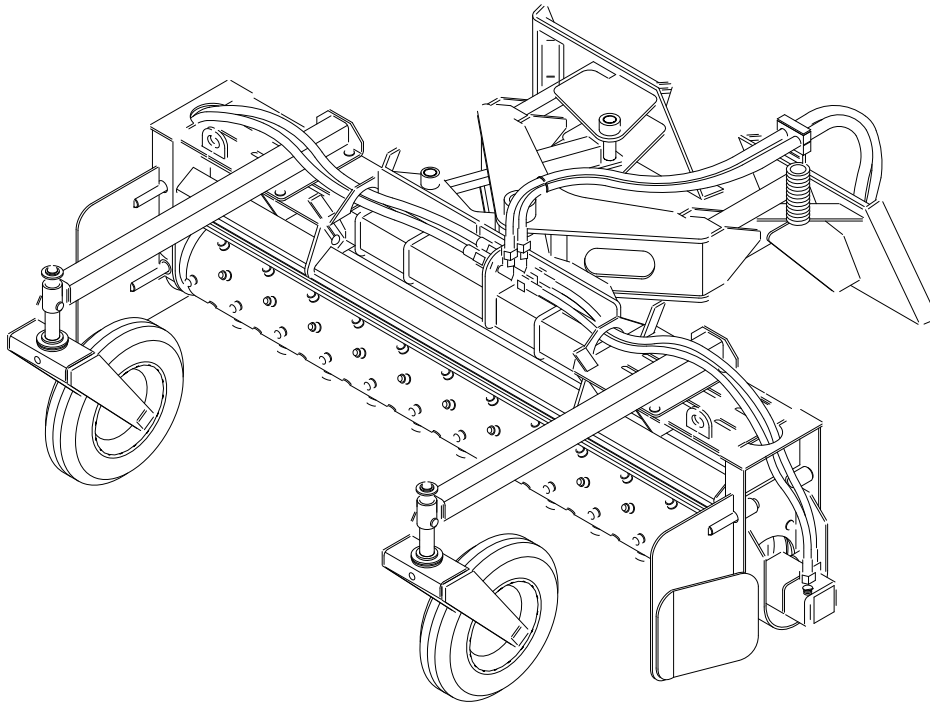

**SERIAL NUMBER:** \_\_\_\_\_

**MODEL NUMBER:** \_\_\_\_\_

**Manual Number:** MR25661

**Models:** LAF5647, LAF5671, LAF5689;  
LAF5648, LAF5672, LAF5690;  
LAF5660, LAF5676, LAF5694;  
LAF5696, LAF5697 & LAF5698

**Date:** March 2014

**Rev. 2**

## Notes

# TABLE OF CONTENTS

PREFACE .....	2
OWNER AND OPERATOR SAFETY INFORMATION	
SAFETY STATEMENTS .....	3
SAFETY PRECAUTIONS .....	3-5
SAFETY SIGNS .....	6-7
SPECIFICATIONS .....	8-9
MOUNTING .....	10
HYDRAULIC CONNECTION .....	11
SET UP .....	12
OPERATION .....	13
MAINTENANCE .....	14-15
SERVICE .....	16
STORAGE .....	17
POWER RAKE PARTS ILLUSTRATION .....	18, 20 & 22
POWER RAKE PARTS LIST .....	19, 21 & 23
PTO POWER RAKE PARTS ILLUSTRATION .....	24, 26 & 28
PTO POWER RAKE PARTS LIST .....	25, 27 & 29
HYDRAULIC ANGLE KIT PARTS ILLUSTRATIONS AND LISTS .....	30
WARRANTY .....	31

# PREFACE

## GENERAL INFORMATION

This product was carefully designed and manufactured to give you many years of dependable service. Only minor maintenance (such as cleaning and lubricating) is required to keep it in top working condition. Be sure to observe all maintenance procedures and safety precautions in this manual and on any safety decals located on the product and on any equipment on which the attachment is mounted.

### WARNING!



**Never let anyone operate this unit without reading the “Safety Precautions” and “Operating Instructions” sections of this manual. Always choose hard, level ground to park the vehicle on and set the brake so the unit cannot roll.**

Unless noted otherwise, right and left sides are determined from the operator’s control position when facing the attachment.

**NOTE: The illustrations and data used in this manual were current (according to the information available to us) at the time of printing, however, we reserve the right to redesign and change the attachment as may be necessary without notification.**

## BEFORE OPERATION

The primary responsibility for safety with equipment falls to the operator. Make sure the equipment is operated only by trained individuals that have read and understand this manual. If there is any portion of this manual or function you do not understand, contact your local authorized dealer or manufacturer to obtain further assistance. Keep this manual available for reference. Provide this manual to any new owners and/or operator’s

### SAFETY ALERT SYMBOL



This is the “Safety Alert Symbol” used by this industry. This symbol is used to warn of possible injury. Be sure to read all warnings carefully. They are included for your safety and the safety of others working with you.

## SERVICE

Use only manufacturer replacement parts. Substitute parts may not meet the required standards. Record the model and serial number of your unit on the cover of this manual. The parts department needs this information to insure that you receive the correct parts.

## SOUND AND VIBRATION

“Sound pressure levels and vibration data for this attachment are influenced by many different parameters; some items are listed below (not inclusive):

- prime mover type, age, condition, with or without cab enclosure and configuration
- operator training, behavior, stress level
- job site organization, working material condition, environment

Based on the uncertainty of the prime mover, operator, and job site, it is impossible to get precise machine and operator sound pressure levels, or vibration levels for this attachment.”

NOTE: A list of all Paladin Patents can be found at <http://www.paladinbrands.com/patents.asp>.

# SAFETY STATEMENTS



**THIS SYMBOL BY ITSELF OR WITH A WARNING WORD THROUGHOUT THIS MANUAL IS USED TO CALL YOUR ATTENTION TO INSTRUCTIONS INVOLVING YOUR PERSONAL SAFETY OR THE SAFETY OF OTHERS. FAILURE TO FOLLOW THESE INSTRUCTIONS CAN RESULT IN INJURY OR DEATH.**



**DANGER**

**THIS SIGNAL WORD IS USED WHERE SERIOUS INJURY OR DEATH WILL RESULT IF THE INSTRUCTIONS ARE NOT FOLLOWED PROPERLY.**



**WARNING**

**THIS SIGNAL WORD IS USED WHERE SERIOUS INJURY OR DEATH COULD RESULT IF THE INSTRUCTIONS ARE NOT FOLLOWED PROPERLY.**



**CAUTION**

**THIS SIGNAL WORD IS USED WHERE MINOR INJURY COULD RESULT IF THE INSTRUCTIONS ARE NOT FOLLOWED PROPERLY.**

**NOTICE**

**NOTICE INDICATES A PROPERTY DAMAGE MESSAGE.**

## GENERAL SAFETY PRECAUTIONS

### **WARNING! READ MANUAL PRIOR TO INSTALLATION**



Improper installation, operation, or maintenance of this equipment could result in serious injury or death. Operators and maintenance personnel should read this manual, as well as all manuals related to this equipment and the prime mover thoroughly before beginning installation, operation, or maintenance. **FOLLOW ALL SAFETY INSTRUCTIONS IN THIS MANUAL AND THE PRIME MOVER'S MANUAL(S).**



### **READ AND UNDERSTAND ALL SAFETY STATEMENTS**

Read all safety decals and safety statements in all manuals prior to operating or working on this equipment. Know and obey all OSHA regulations, local laws, and other professional guidelines for your operation. Know and follow good work practices when assembling, maintaining, repairing, mounting, removing, or operating this equipment.



### **KNOW YOUR EQUIPMENT**

Know your equipment's capabilities, dimensions and operations before operating. Visually inspect your equipment before you start, and never operate equipment that is not in proper working order with all safety devices intact. Check all hardware to ensure it is tight. Make certain that all locking pins, latches, and connection devices are properly installed and secured. Remove and replace any damaged, fatigued, or excessively worn parts. Make certain all safety decals are in place and are legible. Keep decals clean, and replace them if they become worn and hard to read.

## GENERAL SAFETY PRECAUTIONS

### WARNING! PROTECT AGAINST FLYING DEBRIS



Always wear proper safety glasses, goggles or a face shield when driving pins in or out, or when any operation causes dust, flying debris, or any other hazardous material.

### WARNING! LOWER OR SUPPORT RAISED EQUIPMENT



Do not work under raised booms without supporting them. Do not use support material made of concrete blocks, logs, buckets, barrels or any other material that could suddenly collapse or shift positions. Make sure support material is solid, not decayed, warped, twisted, or tapered. Lower booms to ground level or onto blocks. Lower booms and attachments to the ground before leaving the cab or operator's station.

### WARNING! USE CARE WITH HYDRAULIC FLUID PRESSURE



Hydraulic fluid under pressure can penetrate the skin and cause serious injury or death. Hydraulic leaks under pressure may not be visible. Before connecting or disconnecting hydraulic hoses, read your prime movers operator's manual for detailed instructions on connecting and disconnecting hydraulic hoses or fittings.

- Keep unprotected body parts, such as face, eyes, and arms as far away as possible from a suspected leak. Flesh injected with hydraulic fluid may develop gangrene or other permanent disabilities.
- If injured by injected fluid, see a doctor at once. If your doctor is not familiar with this type of injury, ask him to research immediately to determine proper treatment.
- Wear safety glasses, protective clothing, and use a sound piece of cardboard or wood when searching for hydraulic leaks. **DO NOT USE YOUR HANDS!** **SEE ILLUSTRATION.**

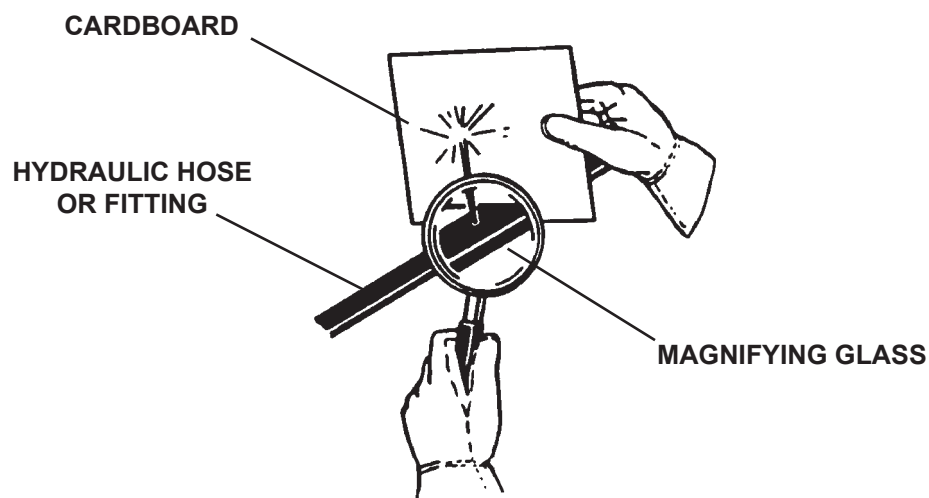

# GENERAL SAFETY PRECAUTIONS

## **WARNING! DO NOT MODIFY MACHINE OR ATTACHMENTS**



Modifications may weaken the integrity of the attachment and may impair the function, safety, life, and performance of the attachment. When making repairs, use only the manufacturer's genuine parts, following authorized instructions. Other parts may be substandard in fit and quality. Never modify any ROPS (Roll Over Protection Structure) or FOPS (Falling Object Protective Structure) equipment or device. Any modifications must be authorized in writing by the manufacturer.

## **WARNING! SAFELY MAINTAIN AND REPAIR EQUIPMENT**



- Do not wear loose clothing, or any accessories that can catch in moving parts. If you have long hair, cover or secure it so that it does not become entangled in the equipment.
- Work on a level surface in a well-lit area.
- Use properly grounded electrical outlets and tools.
- Use the correct tool for the job at hand. Make sure they are in good condition for the task required.
- Wear the protective equipment specified by the tool manufacturer.

## **WARNING! SAFELY OPERATE EQUIPMENT**



Do not operate equipment until you are completely trained by a qualified operator in how to use the controls, know its capabilities, dimensions, and all safety requirements. See your machine's manual for these instructions.

- Keep all step plates, grab bars, pedals, and controls free of dirt, grease, debris, and oil.
- Never allow anyone to be around the equipment when it is operating.
- Do not allow riders on the attachment or the prime mover.
- Do not operate the equipment from anywhere other than the correct operators position.
- Never leave equipment unattended with the engine running or with this attachment in a raised position.
- Do not alter or remove any safety feature from the prime mover or this attachment.
- Know your work site safety rules as well as traffic rules and flow. When in doubt on any safety issue, contact your supervisor or safety coordinator for an explanation.

## **WARNING! KNOW WHERE UTILITIES ARE**



Observe overhead electrical and other utility lines. Be sure equipment will clear them. When digging, call your local utilities for location of buried utility lines, gas, water, and sewer, as well as any other hazard you may encounter.

# SAFETY SIGN LOCATIONS

The diagram on this page shows the location of the decals used on the FFC Power Rake. The decals are identified by their part numbers, with reductions of the actual decals located on the following page. Use this information to order replacements for lost or damaged decals. Be sure to read all decals before operating the attachment. They contain information you need to know for both safety and product longevity.

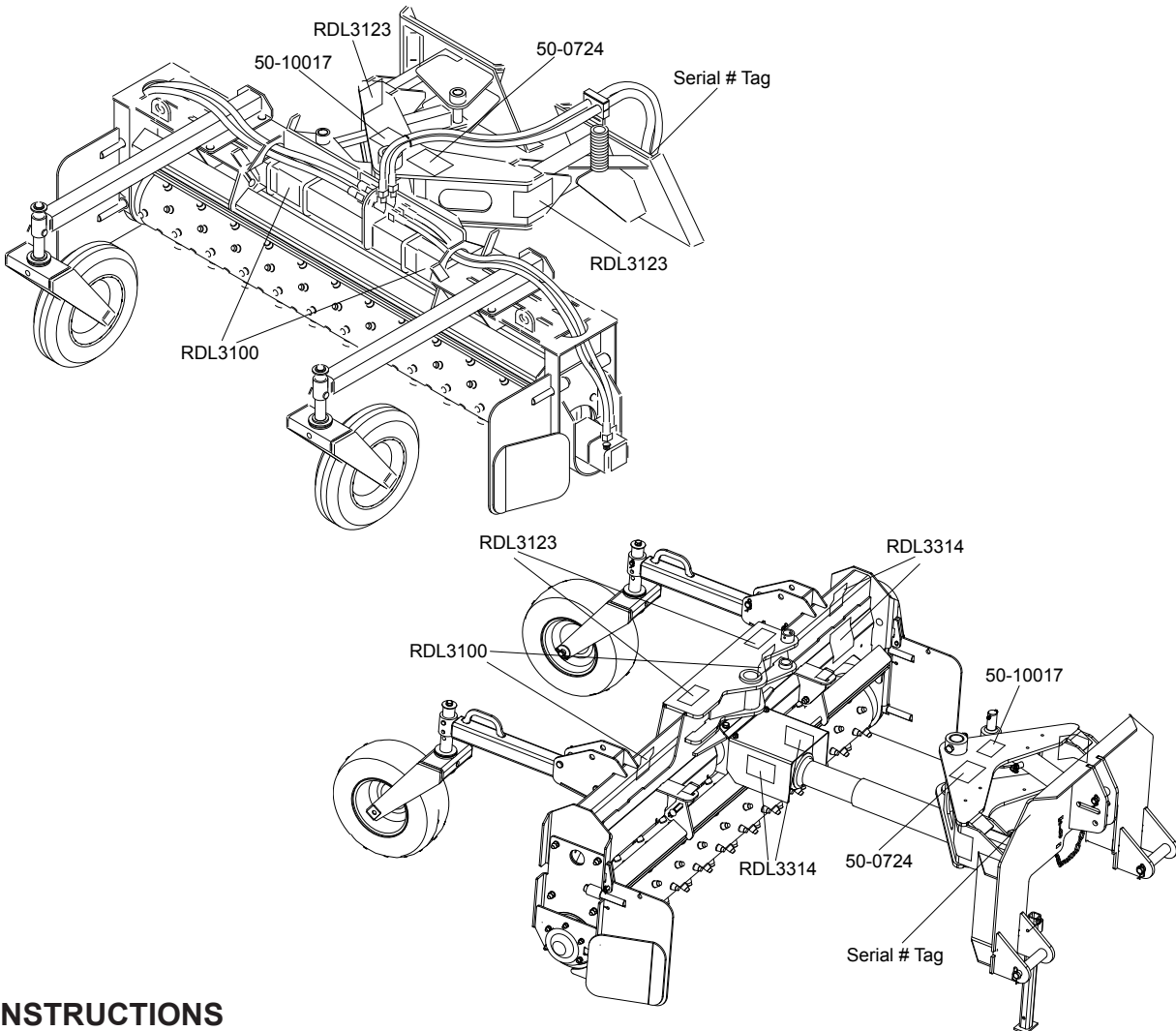

## INSTRUCTIONS

- Keep all safety signs clean and legible.
- Replace all missing, illegible, or damaged safety signs.
- Replacement parts for parts with safety signs attached must also have safety signs attached.
- Safety signs are available, free of charge, from your dealer or from FFC.

## PLACEMENT OR REPLACEMENT OF SAFETY SIGNS

1. Clean the area of application with non-flammable solvent, and then wash the same area with soap and water.
2. Allow the surface to fully dry.
3. Remove the backing from the safety sign, exposing the adhesive surface.
4. Apply the safety sign to the position shown in the diagram above and smooth out any bubbles.



# SAFETY SIGNS



PART #50-0724  
WARNING! HIGH PRESSURE FLUID

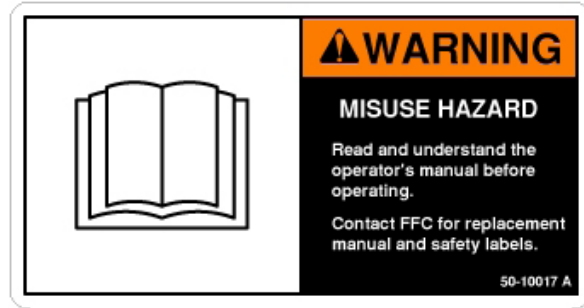

PART #50-10017  
WARNING! READ MANUAL



PART #RDL3100  
WARNING! STAND CLEAR



PART #RDL3123  
WARNING! PIVOTING ATTACHMENT



PART #RDL3314  
DANGER! ROTATING SHAFT

## PRIME MOVER SPECIFICATIONS

**IMPORTANT** Exceeding any of the maximum recommended prime mover specifications **CAN** result in damage to this product and **WILL** void all FFC warranties.

DESCRIPTION	SPECIFICATIONS
Weight of Prime Mover without Power Rake	11,000 lbs. maximum
Operating Capacity of Prime Mover's Loader	4,500 lbs. maximum
Lift Capacity of Prime Mover's Loader	9,000 lbs. maximum
Hydraulic Pressure Output	3,500 psi maximum
Rear Ballast	As required to maintain full prime mover stability. (Note the Shipping Weight on the specifications page, then see the operator's manual(s) for your prime mover, loader, and quick-attach for ballasting needs.)

## TRACTOR REQUIREMENTS

The PTO Drive Units are designed for use with tractors that are equipped with an 1.38"-6 spline rear power take-off (PTO), **540 rpm only**.

The tractor must also provide for 3-point hitch attachment Category I or II. The tractors rated drawbar PTO horsepower on a 3-point should be no less than 25 HP and no more than 100 HP.

**NOTE:** In order to maintain steering control, ballast may need to be added to you tractor. To determine whether or not to add the ballast, refer to your tractor's operator's manual.

## POWER RAKE SPECIFICATIONS

Model Number	Overall Width	Overall Height	Overall Depth	Shipping Weight
LAF5648 (MANUAL)	60.63"	30.31"	72.5"	870 lbs.
LAF5648H (HYDRAULIC)	60.63"	30.31"	72.5"	905 lbs.
LAF5672 (MANUAL)	82.75"	30.31"	72.5"	1000 lbs.
LAF5672H (HYDRAULIC)	82.75"	30.31"	72.5"	1035 lbs.
LAF5690 (MANUAL)	100.75"	30.31"	72.5"	1075 lbs.
LAF5690H (HYDRAULIC)	100.75"	30.31"	72.5"	1110 lbs.
LAF5660 (HYDRAULIC)	68.13"	38.75"	95"	1150 lbs.
LAF5696 (MANUAL)	68.13"	38.75"	95"	1115 lbs.
LAF5676 (HYDRAULIC)	84.13"	38.75"	95"	1220 lbs.
LAF5697 (MANUAL)	84.13"	38.75"	95"	1185 lbs.
LAF5694 (HYDRAULIC)	102.13"	38.75"	95"	1290 lbs.
LAF5698 (MANUAL)	102.13"	38.75"	95"	1255 lbs.



# BOLT TORQUE SPECIFICATIONS

## GENERAL TORQUE SPECIFICATION TABLES

Use the following charts when determining bolt torque specifications when special torques are not given. Always use grade 5 or better when replacing bolts.



## SAE BOLT TORQUE SPECIFICATIONS

**NOTE:** The following torque values are for use with extreme pressure lubricants, plating or hard washer applications. Increase torque 15% when using hardware that is unplated and either dry or lubricated with engine oil.

Bolt Size		SAE GRADE 5 TORQUE				SAE GRADE 8 TORQUE				Bolt head identification marks as per grade. NOTE: Manufacturing Marks Will Vary
		Pounds Feet		Newton-Meters		Pounds Feet		Newton-Meters		
Inches	Millimeters	UNC	UNF	UNC	UNF	UNC	UNF	UNC	UNF	
1/4	6.35	8	9	11	12	10	13	14	18	<p>GRADE 2</p>  <p>GRADE 5</p>  <p>GRADE 8</p> 
5/16	7.94	14	17	19	23	20	25	27	34	
3/8	9.53	30	36	41	49	38	46	52	62	
7/16	11.11	46	54	62	73	60	71	81	96	
1/2	12.70	68	82	92	111	94	112	127	152	
9/16	14.29	94	112	127	152	136	163	184	221	
5/8	15.88	128	153	174	207	187	224	254	304	
3/4	19.05	230	275	312	373	323	395	438	536	
7/8	22.23	340	408	461	553	510	612	691	830	
1	25.40	493	592	668	803	765	918	1037	1245	
1-1/8	25.58	680	748	922	1014	1088	1224	1475	1660	
1-1/4	31.75	952	1054	1291	1429	1547	1700	2097	2305	
1-3/8	34.93	1241	1428	1683	1936	2023	2312	2743	3135	
1-1/2	38.10	1649	1870	2236	2535	2686	3026	3642	4103	

## METRIC BOLT TORQUE SPECIFICATIONS

**NOTE:** The following torque values are for use with metric hardware that is unplated and either dry or lubricated with engine oil. Reduce torque 15% when using hardware that has extreme pressure lubricants, plating or hard washer applications.

Bolt head identification marks as per grade.		
		

Size of Bolt	Grade No.	Pitch (mm)	Pounds Feet	Newton-Meters	Pitch (mm)	Pounds Feet	Newton-Meters
M6	5.6	1.0	3.6-5.8	4.9-7.9	-	-	-
	8.8		5.8-4	7.9-12.7		-	-
	10.9		7.2-10	9.8-13.6		-	-
M8	5.6	1.25	7.2-14	9.8-19	1.0	12-17	16.3-23
	8.8		17-22	23-29.8		19-27	25.7-36.6
	10.9		20-26	27.1-35.2		22-31	29.8-42
M10	5.6	1.5	20-25	27.1-33.9	1.25	20-29	27.1-39.3
	8.8		34-40	46.1-54.2		35-47	47.4-63.7
	10.9		38-46	51.5-62.3		40-52	54.2-70.5
M12	5.6	1.75	28-34	37.9-46.1	1.25	31-41	42-55.6
	8.8		51-59	69.1-79.9		56-68	75.9-92.1
	10.9		57-66	77.2-89.4		62-75	84-101.6
M14	5.6	2.0	49-56	66.4-75.9	1.5	52-64	70.5-86.7
	8.8		81-93	109.8-126		90-106	122-143.6
	10.9		96-109	130.1-147.7		107-124	145-168
M16	5.6	2.0	67-77	90.8-104.3	1.5	69-83	93.5-112.5
	8.8		116-130	157.2-176.2		120-138	162.6-187
	10.9		129-145	174.8-196.5		140-158	189.7-214.1
M18	5.6	2.0	88-100	119.2-136	1.5	100-117	136-158.5
	8.8		150-168	203.3-227.6		177-199	239.8-269.6
	10.9		175-194	237.1-262.9		202-231	273.7-313
M20	5.6	2.5	108-130	146.3-176.2	1.5	132-150	178.9-203.3
	8.8		186-205	252-277.8		206-242	279.1-327.9
	10.9		213-249	288.6-337.4		246-289	333.3-391.6

# POWER RAKE MOUNTING

## **WARNING! READ MANUAL PRIOR TO INSTALLATION**



Improper installation, operation, or maintenance of this equipment could result in serious injury or death. Operators and maintenance personnel should read this manual, as well as all manuals related to this equipment and the prime mover thoroughly before beginning installation, operation, or maintenance. **FOLLOW ALL SAFETY INSTRUCTIONS IN THIS MANUAL AND THE PRIME MOVER'S MANUAL(S).**

### **Loaders**

1. Place this product on a firm, level surface that is large enough to safely accommodate this product, your prime mover and all workers involved in the mounting process.
2. Refer to the operator's manual(s) for your prime mover, loader, and quick-attach and follow the mounting instructions contained therein.
3. Carefully raise the loader arms or three point linkage and cycle the tilt cylinders or lower link arms to check clearances and to verify that all mounting procedures have been successfully completed.

**IMPORTANT** Lubricate all grease fittings before connecting this product to your prime mover's hydraulic system. Refer to **POWER RAKE MAINTENANCE** page and follow the instructions.

### **3 Point Hitch Category 1 or 2**

1. Place this product on a firm, level surface that is large enough to safely accommodate this product, your tractor, and all workers involved in the mounting process. Making sure this product is in the operating position and level will facilitate in selecting the proper mounting holes.
2. Read and understand the Operation and Maintenance manual for your tractor before installing this product.
3. Remove the top link on your tractors' 3 point and drive the tractor backwards in to position to connect the lower links to the attachment mounting ears. The ears have a combination category 1 & 2 hitch pin installed so you need to make sure the outer pin matches your tractors' category. Select a hole position on the mounting ears that aligns or is a little above the lower link points with the tractor link arms fully lowered and connect the arms.
4. The upper link cylinder provided with this product requires a category #2, 1" diameter pin to attach to the tractors' upper link point. If you have a category #1 tractor you will have to bush the pin up to category #2. It is important that when you pin the rod end of the cylinder to the tractors' upper link point there is between 4" and 5" of exposed cylinder rod. If you have less the bucket will not roll back enough and if you have more the bucket will not dump properly. Move the cylinder pin hole position on the mounting ears until you attain the recommended amount of exposed cylinder rod.

**IMPORTANT** Lubricate all grease fittings before connecting this product to your prime mover's hydraulic system. Refer to **POWER RAKE MAINTENANCE** page and follow the instructions.

# POWER RAKE HYDRAULIC CONNECTION



## READ AND UNDERSTAND ALL SAFETY STATEMENTS

Read all safety decals and safety statements in all manuals before beginning any Power Rake hydraulic connection. Know and obey all OSHA regulations, local laws, and other professional guidelines for your operation. Know and follow good work practices when assembling, maintaining, repairing, mounting, removing, or operating this equipment.

### Loaders

1. Disconnect the hydraulic hose quick couplers (or purchase locally, if not supplied) from one another and attach the quick couplers to your prime mover as per the instructions in your prime mover's operator's manual.
2. Carefully raise the loader arm and cycle the tilt cylinders or lower link to check hose clearances and to check for any interference.
3. If your Power Rake is equipped with a hydraulic angling kit (LAF5640/LAF5650), connect the two eye terminal wire ends (black = positive / white = negative) to the prime mover battery. The angle cylinder is activated by the toggle switch ONLY when the drum is turning clockwise [viewed from the left end]. The toggle switch box is magnetized and should be placed on a convenient steel surface in the cab of the prime mover. If your unit is equipped with a quick connect wire harness for the prime mover joystick refer to owner's manual for proper installation and operation.
4. Cycle the hydraulic cylinder(s) on this product several times from fully retracted to fully extended until all air has been completely removed from the cylinder(s).

### 3 Point Hitch Category 1 or 2

1. **Both the hydraulic drive and the PTO drive require one set of auxiliary hydraulics.** Purchase proper couplers and hoses and attach to the tractor per the instructions in your tractors' operators manual.
2. Carefully raise the link arms and cycle the upper link cylinder to check hose clearances, interferences, and acceptable range of motion to operate the Power Rake.

**NOTICE** When shipped, the hydraulic cylinder(s) on this product contained air or an air-fluid mixture. The orifices beneath the port(s) of the cylinder barrels will restrict the exit of that air. Failure to remove all the air from the hydraulic cylinder(s) can cause uneven, jerky cylinder movement when the hydraulic controls are being operated and unwanted cylinder movement when the controls are not being operated.

**WARNING!** Do not lock the auxiliary hydraulics of your prime mover in the "ON" position. Failure to obey this warning could result in death or serious injury.



# POWER RAKE SETUP



**SAFETY FIRST! READ AND UNDERSTAND THE SAFETY INSTRUCTIONS BEFORE BEGINNING ANY POWER RAKE SETUP!**

## 1. Roller

The roller and power rake [front to back] should be positioned level with the ground. To adjust, raise or lower the gauge wheels and/or use the prime mover's tilt cylinder. For a 3-point mounting, the upper link needs to be adjusted in or out.

To allow the roller to penetrate the ground deeper, raise the gauge wheels. During operation, depth control can be adjusted further by tilting the power rake back to raise the gauge wheels, allowing more roller penetration.

## 2. Deflectors

Under average conditions, the normal gap between the roller and deflector should be about 1.25". This gap can be adjusted by loosening the two carriage bolts that hold the deflector and adjusting it up or down in the square cornered slot. A wider opening will allow more dirt and rock to pass through. DO NOT let the roller hit the deflector. The gap should be consistent all across the deflector and this can be verified by either measuring or matching height marks on the two tabs that protrude up through a slot in the deflector support area.

## 3. Endplates

The endplates contain the material in front of the roller while clean material passes between the roller and deflector. With the endplates mounted in the working position and the power rake parallel with the prime mover's tires, material can be moved along, filling in low spots.

Hydraulic drive unit endplates can be mounted to the front or back of the power rake, depending on raking direction. When moving the endplates from front to back, move the left one to the right side and the right one to the left side. Pin the top bushing only to secure the endplates. For PTO drive units the endplate mounting is limited to containment when traveling forward only.

The endplates can be stored by using the top front bushing and storage tab or tabs on the mainframe.

## 4. Angle

Set the rake straight for conditioning and collecting debris.

Angle the rake for windrowing debris or fill. Angling is also used to change grade.



# POWER RAKE OPERATION

**WARNING!** Failure to obey the following procedures could result in death or serious injury.

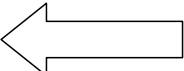

- Never lift this product above (a) the operator's eye level or (b) to a height where visibility is obstructed, whichever is lower.

1. Never raise the Power Rake more than a few inches off the ground when traveling from job site to job site.
2. For the roller to operate effectively, it must rotate in the opposite direction of the prime mover wheels [see figure below]. Roller direction is controlled by prime mover hydraulic controls or PTO shaft. PTO shaft rotation cannot be reversed and results in roller rotation shown in the lower illustration.

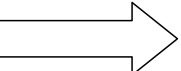
Roller Rotation	Travel Direction
	
	

3. Normal operating ground speed is between 3 and 5 mph. In heavy rock, reduce speed to 1 to 3 mph.
4. For hydraulic drive, normal operating rpm of the roller is approximately 170. If operating in heavy rock, reduce speed as appropriate. For PTO drive the drum rpm is constant at 211 at 540 PTO rpm.
5. Operating depth will determine how much dirt is carried ahead of the roller. Ideal depth will vary from skimming the surface to about 3" deep.
6. When making the first windrow, the level of dirt may be halfway up the deflector. After moving the windrow two or three times, the level of dirt may be to the top of the deflector. Try to prevent material from flowing over the top of the deflector. Volume and density of material will dictate how many times a windrow can be moved.
7. The following are common operating applications:

Application	Roller Position	Endplate Position	Hydraulic Float Position*
Pulverizing topsoil	Angled or Straight	Stored	Rigid
Debris Removal	Angled or Straight	Windrow or Collect	Float
Finish Grading	Straight	Collect	Float
Spreading Fill and Topsoil	Angled	Windrow	Rigid
Changing Grade	Angled	Windrow	Float
Thatching existing Grass Area	Straight	Stored	Rigid

\*See your prime mover's manual for whether or not your loader has hydraulic float capabilities. For models with 4-bar linkages, remove the clevis pin (part # 96) to float. (pins may be stored in the middle position holes of the back plate ribs.) For PTO drive models connect the upper link at the slotted mast hole.

8. When adjusting the gap between the roller and deflector; a wider opening will allow more dirt and rock to pass through. For finer raking, reduce the gap.
9. Tires: check the air pressure of your tires before each use. Maintain recommended tire pressure to maintain a consistent, even grade.

# POWER RAKE MAINTENANCE

## GENERAL INFORMATION

Regular maintenance is the key to long equipment life and safe operation. Maintenance requirements have been reduced to the absolute minimum. However, it is very important that these maintenance functions be performed as described below.

1. Park your prime mover on a level surface with this product properly attached.
2. Place your prime mover's transmission in "Park" and engage the parking brake.
3. Lower this product onto preplaced blocking.
4. Shut off your prime mover's engine, remove the starter key, wait for all moving parts to come to a stop, and relieve all pressure in the hydraulic lines (refer to your prime mover's operator's manual for instructions on how to relieve hydraulic pressure). On PTO drive models disconnect the driveline.

**WARNING!**  Do not use blocking made of concrete blocks, logs, buckets, barrels or any other material that could suddenly collapse or shift positions. Do not use wood or steel blocking that is warped, twisted, or tapered. Failure to obey this warning could result in death or serious injury.

## BEFORE EACH USE

- Make sure all shielding is in place.
- On PTO drive models check driveline for wear.
- Make sure that all nuts and bolts are in place and properly tightened.
- Make sure that all other fasteners are in place and are performing their specified function.
- Make sure that tires are inflated to maximum load pressure indicated on tire. Do not over inflate.
- Make sure that all hydraulic fittings are tightened to specifications and that there are no leaks in any fittings or hoses. (SEE THE HYDRAULIC CONNECTION SECTION).
- Make sure that all safety signs are in place, are clean, and are legible. (SEE THE SAFETY SIGN SECTION).
- Replace any damaged parts and excessively worn parts.

## AFTER EVERY 10 HOURS OF USE ON PTO DRIVE MODELS

- Grease roller bearing (48" and PTO drive models only). Grease all u-joint cross bearings. The main frame shaft guard must be removed to grease the hex driveline.

## WEEKLY

- Lubricate all pivot points, PTO driveline guard, and PTO driveline telescoping shafts.

## FOR PTO DRIVE – AFTER 50 HOURS OF USE AND THEN EVERY 1000 HOURS OR ANNUALLY

- Drain the 90 degree gearbox and the spur gear case of lubricant and refill with 80-90 W gear lube with an EP rating of GL-5 minimum. (Approximately 41 oz. For the 90 degree gearbox and 63 oz. For the spur gear case.)

## ANNUALLY

Repack the bearings in the wheels as described in steps 1-4 below.

1. Make sure that there is no weight on the wheels. If the wheels are partially supporting the weight of this product, restart your prime mover and move the loader and/or dump cylinders. Repeat the specified shutdown procedure.
2. Remove each wheel using two wrenches and remove the bearing components from the wheels.
3. Clean the bearing components, and then use a high quality waterproof grease to repack the bearing components & hub.
4. Reassemble all components using a new seal.





# POWER RAKE SERVICE

**IMPORTANT** When replacing parts use only factory approved replacement parts. Manufacturer will not claim responsibility for use of unapproved parts or accessories and/or other damages as a result of their use.

## Removing Wire, Twine, Weeds, etc. that are Wrapped Around the Roller

1. Park your prime mover on a level surface with this product properly attached.
2. Place your prime mover's transmission in "Park" and engage the parking brake. On PTO models make sure PTO is disengaged.
3. Lower this product onto preplaced blocking that will support the motor guards of this product so that the teeth are not in contact with the ground.

**WARNING!**  Do not use blocking made of concrete blocks, logs, buckets, barrels or any other material that could suddenly collapse or shift positions. Do not use wood or steel blocking that is warped, twisted, or tapered. Failure to obey this warning could result in death or serious injury.

4. Shut off your prime mover's engine, remove the starter key, wait for all moving parts to come to a stop, and relieve all pressure in the hydraulic lines.
5. Disconnect the hydraulic lines from your prime mover and connect the two ends to each other. For PTO drive disconnect the PTO driveline. This should permit the roller to rotate freely.
6. Pull the material from the roller while allowing it to rotate.

## **ALTERNATE METHOD FOR SKID STEER LOADERS**

If your prime mover is equipped with safety stops for the lift arms of the loader that can be activated from the operator's position or if the safety stops must be activated from outside the operator's position and a second person is present, then the method above may be replaced with these steps:

1. Park your prime mover on a level surface with this product properly attached.
2. Place your prime mover's transmission in "Park" and engage the parking brake.
3. Disconnect the hydraulic lines from your prime mover and connect the two ends to each other. This should permit the roller to rotate freely.
4. Fully raise the lift arms and fully extend the tilt cylinders to the fully dumped position.
5. Shut off your prime mover's engine, remove the starter key, wait for all moving parts to come to a stop, and relieve all pressure in the hydraulic lines.
6. Pull the material from the roller while allowing it to rotate.

## Replacing Deflector Strips

1. Perform steps 1 through 5 above.
2. Remove worn strip by removing bolts and nuts that secure the strip.
3. Replace the strip, making sure the steel backing strip is re-installed.

**IMPORTANT:** For PTO Drive Models genuine FFC replacement parts must be used to service the PTO driveline.

## POWER RAKE STORAGE



**SAFETY FIRST!! READ AND UNDERSTAND THE SAFETY INSTRUCTIONS BEFORE BEGINNING ANY POWER RAKE STORAGE**

1. Disconnect hydraulic hoses from prime mover. Install dust plugs or couple hoses together, as appropriate.
2. Disengage your Power Rake from the prime mover. Be sure your Power Rake rests in a stable position for storage.
3. Be sure your power rake is stored on a hard, level surface.

**WARNING! Block equipment securely for storage.**



**WARNING! Keep children and bystanders away from storage area.**





## POWER RAKE PARTS LIST

ITEM	QTY.	LAF5647 LAF5648 48"	LAF5671 LAF5672 72"	LAF5689 LAF5690 90"	DESCRIPTION
1	varies	(1)	(2)	(2) 13-50860	Motor Mount
2	1	13-50861	Not Used	Not Used	Axle Shaft Assembly (for 48" model)
3	varies	(1)	(2)	(2) 13-50865	Motor Plate
4	2			13-50866	Wheel Arm
5	1	13-51048	Not Used	Not Used	Bearing Mount (for 48" model)
6	1			LAF2817	Position Tube (Female)
7	1			LAF2818	Position Tube (Male)
8	varies	(3)	(6)	(6) LAF3412	Shroud Gusset Protector
9	2	Not Used		LAF4075	Bulkhead Jam Nut #10
*10	1			03-3859	Hydraulic Quick Coupler Female 12FB
*11	1			03-3860	Hydraulic Quick Coupler Male 12FB
*12	2			03-4618	Hydraulic Adapter 10FB-12MB
13	varies	(2)	(4)	(4) P276200	Hydraulic Adapter 10MB-10MJ
14	2	Not Used		LAF4656	Hydraulic Tee Bulkhead Run 10MJ-10MJ-10MJ
15	varies	(1) LAF4655	(2) LAF4678	(2) LAF4678	Hydraulic Motor
16	2	LAF4514 (92)	LAF4680 (96)	LAF4680 (96)	Hydraulic Hose .63" x Length noted 10FJ-12MB
17	2	Not Used	LAF4657 (48)	LAF4682 (57)	Hydraulic Hose .5" x Length noted 10FJ-10FJ
18	2	Not Used	LAF4682 (57)	LAF4709 (66)	Hydraulic Hose .5" x Length noted 10FJ-10FJ
**19	1			LAF5600	Mounting Frame
20	1			LAF5602	Pivot Pin
21	2	LAF5609	LAF5633	LAF5603	Drum Deflector
22	1	LAF5608	LAF5631	LAF5605	Main Frame (Hydraulic Drive)
23	1	LAF5606	Not Used	Not Used	Dust Guard (for 48" model)
24	1			LAF5613	Right Side Shield
25	2			M6817	Wheel Caster Fork
26	2			P850620	Wheel Caster Washer (top)
27	4			LAF5625	Wheel Bearing Seal
28	1	LAF5618	LAF5630	LAF5626	Drum Weldment
29	2	LAF5610	LAF5634	LAF5627	Drum Deflector Strap
30	1			LAF5628	Pivot Frame
31	2			LAF5629	Wheel Caster Washer (bottom)
32	2	LAF5616	LAF5632	LAF5635	Deflector Support
33	1			LAF5636	Left Side Shield
34	2			LAF5638	Wheel Post
35	1	LAF6808	Not Used	Not Used	Rotor Bearing (for 48" model)
36	4			P760500	Bearing Race

**NOTE: All parts are the same as the LAF5690 except for those parts numbered under the other models.**

**\*ITEM may vary per Prime Mover -- Contact FFC for correct item.**

**\*\*For Floating Models (LAF5647, LAF5671 & LAF5689) see part numbers 90-96.**

# POWER RAKE PARTS ILLUSTRATION

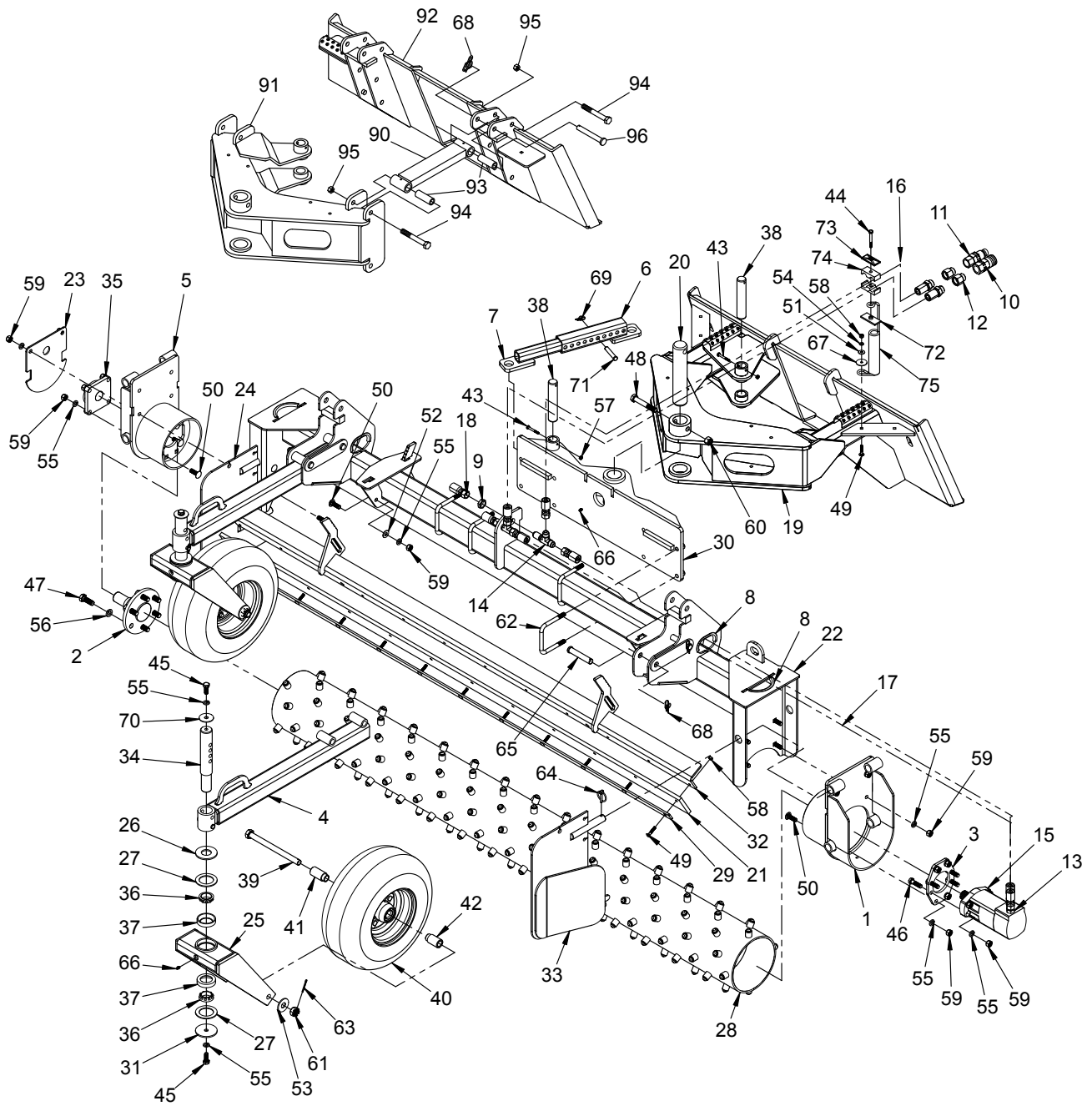

## POWER RAKE PARTS LIST

ITEM	QTY.	LAF5647 LAF5648 48"	LAF5671 LAF5672 72"	LAF5689 LAF5690 90"	DESCRIPTION
37	4			P760300	Tapered Roller Bearing Cone
38	2			LAF9715	Pin 1.25" x 6.5" (1) .281 Hole
39	2			M10463	Axle Bolt .75"-16 x 9.5" Fine Thread Hex
40	2			M16107	Wheel and Tire Assembly
41	2			M16108	Axle Spacer Long
42	2			M16109	Axle Spacer Short
43	2			07-3022	Grade 8 Hex Head Cap Screw .25" x 2"
44	1			RHW1112	Grade 5 Hex Head Cap Screw .31" x 2.5"
45	4			P100805	Grade 5 Hex Head Cap Screw .5" x 1.25"
46	varies	(4)	(8)	(8) RHW1406	Grade 5 Hex Head Cap Screw .5" x 1.75"
47	6	RHW1603	Not Used	Not Used	Grade 5 Hex Head Cap Screw .63" x 1.75"
48	1			RHW1612	Grade 5 Hex Head Cap Screw .63" x 4"
49	varies	(12)	(18)	(24) P104506	Grade 5 Carriage Bolt .31" x 1.5"
50	20			RHW2405	Grade 5 Carriage Bolt .5" x 1.5"
51	1			RHW5162	Grade 5 Flat Washer .31" USS
52	12			RHW5432	Grade 5 Flat Washer .5" SAE (quantity may vary)
53	2			P850612	Grade 5 Flat Washer .75" USS
54	varies	(13)	(19)	(25) P851105	Grade 5 Lock Washer .31"
55	40			P851108	Grade 5 Lock Washer .5"
56	6	RHW6602	Not Used	Not Used	Grade 5 Lock Washer .63" (for 48" model)
57	2			RHW7003	Grade 5 Lock Nut .5"
58	varies	(13)	(19)	(25) RHW7101	Grade 5 Hex Nut .31" (quantity may vary)
59	varies	(32)	(36)	(36) RHW7401	Grade 5 Hex Nut .5"
60	1			RHW7602	Grade 5 Nylock Nut .63"
61	2			P158000	Grade 5 Hex Slotted Nut .75"-16 Plated
62	4			RHW7999	Grade 5 U-Bolt .5" x 4.25" x 4.03"
63	2			07-1044	Grade 2 Cotter Pin .13" x 1.5"
64	2			RHW8068	Lynch Pin .25" x 1.56" (1.31" Usable)
65	4			RHW8069	Clevis Pin .75" x 4" (3.73" Usable)
66	3			07-3112	Grease Zerk .25" self-tapping (28 tpi)
67	1			RHW8098	Grade 2 Fender Washer .08" x .31" x 1.5"
68	4			RHW8115	Rue Ring Cotter Pin .75" Heavy
69	3			RHW8133	Rue Ring Cotter Pin .5" Heavy
70	2			RHW8136	Washer .5" x 2" OD x .093" Thick
71	3			RHW8150	Clevis Pin .5" x 2.75" (2.53" Usable) Plated
72	1			RHW8613	Weld Plate for .88" Hose (not used on all models)
73	1			RHW8614	Cover Plate for .88" Hose (not used on all models)
74	2			RHW8616	Hose Cradle for .88" Hose (not used on all models)
75	1			RHW8618	Hose Spring (not used on all models)

**NOTE: All parts are the same as the LAF5690 except for those parts numbered under the other models.**

# POWER RAKE PARTS ILLUSTRATION

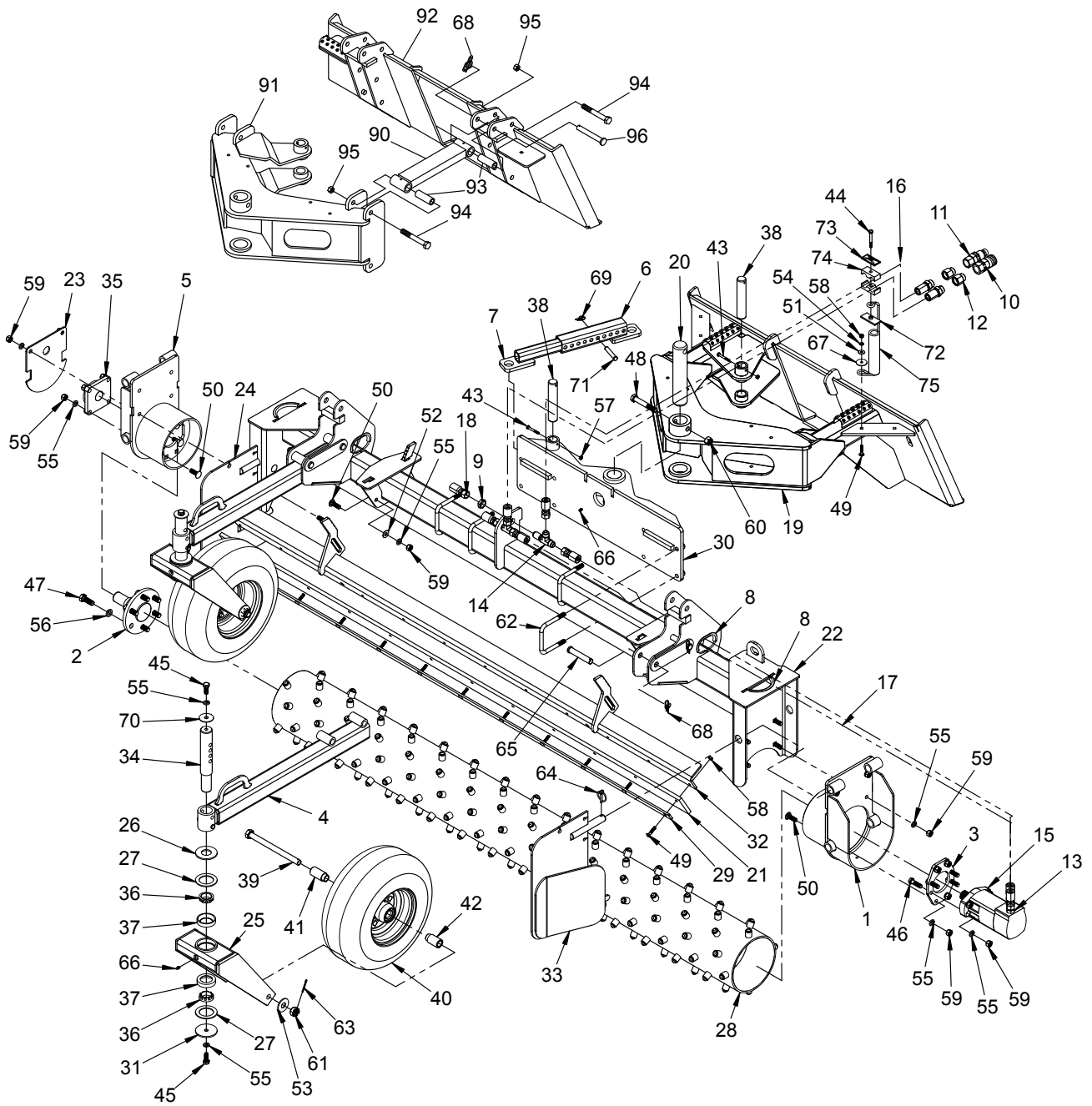



## POWER RAKE PARTS LIST

ITEM	QTY.	LAF5647 48"	LAF5671 72"	LAF5689 90"	DESCRIPTION
90	4			LAF5619	Link Arm
91	1			LAF5639	Mounting Frame
92	1			LAF5641	Back Plate
93	8			LAF5643	Bushing
94	8			P101020	Grade 5 Hex Head Cap Screw .63" x 5"
95	8			RHW7603	Grade 5 Lock Nut .63"
96	2			RHW8148	Clevis Pin .63" x 4.75"

**NOTE: All parts are the same as the LAF5689 except for those parts numbered under the other models.**

# PTO POWER RAKE PARTS ILLUSTRATION

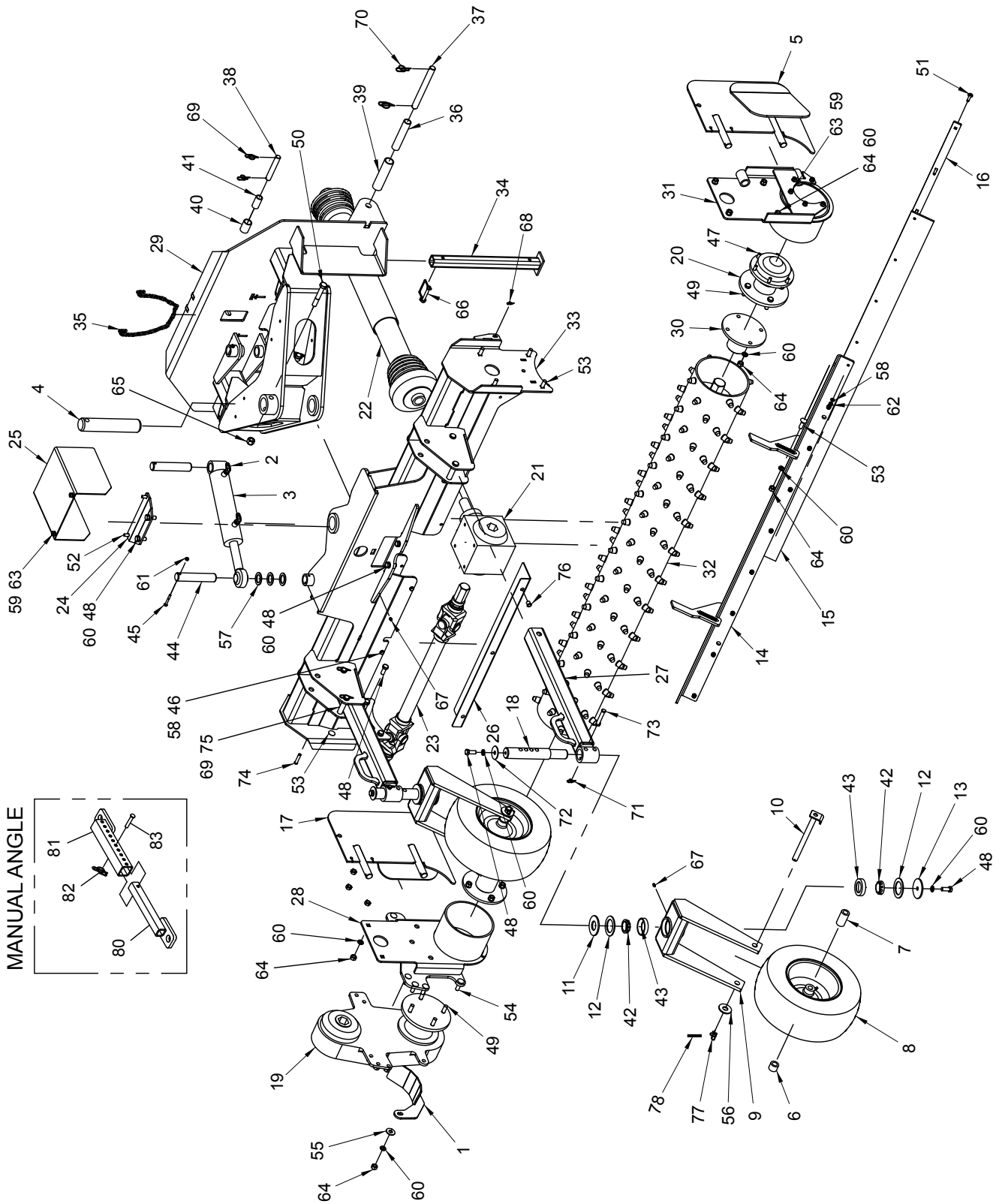

## PTO POWER RAKE PARTS LIST

ITEM	QTY.	LAF5660 56"	LAF5676 72"	LAF5694 90"	DESCRIPTION
1	1			13-50412	PTO Gear Box Guard Weldment
2	2			P261350	Hydraulic Elbow 90° 6MB-6MJ
3	1			LAF4516	Hydraulic Cylinder 2.5" x 7.5" x 1.25" Shaft (Cylinder Seal Kit = LAF4017)
4	1			LAF5602	Pivot Pin
5	1			LAF5613	Right Side Shield
6	2			M16109	Axle Spacer Short
7	2			M16108	Axle Spacer Long
8	2			M16107	Wheel and Tire Assembly
9	2			M6817	Wheel Caster Fork
10	2			M10463	Wheel Axle
11	2			P850620	Wheel Caster Washer (top)
12	4			LAF5625	Wheel Bearing Seal
13	2			LAF5629	Wheel Caster Washer (bottom)
14	1	LAF5687	LAF5632	LAF5635	Deflector Support
15	1	LAF5688	LAF5633	LAF5603	Drum Deflector
16	1	LAF5692	LAF5634	LAF5627	Drum Deflector Strap
17	1			LAF5636	Left Side Shield
18	2			LAF5638	Wheel Post
19	1			LAF5644	Spur Gear Case
20	1			LAF5645	Bearing Assembly
21	1			LAF5646	90° Gear Box
22	1			07-10124	PTO Drive Shaft
23	1	LAF5661	LAF5662	LAF5663	Hex Drive Line
24	1			LAF5664	Spacer Plate
25	1			LAF5665	Clutch Guard
26	1	LAF5667	LAF5668	LAF5669	Shaft Guard
27	2			LAF5670	Wheel Arm
28	1			13-51051	Gear Case Mount
29	1			LAF5677	Mounting Frame
30	2			LAF5678	Hub Mount
31	1			13-51049	Bearing Mount
32	1	LAF5680	LAF5681	LAF5682	Drum Weldment
33	1	LAF5683	LAF5684	LAF5685	Main Frame
34	1			LAF8350	Jack Stand
35	1			LAF9010	Chain .125" GR 30 (26 Links)
36	2			LAF9429	Bushing 1.13" x .13" x 5.56"
37	2			LAF9430	Pin .88" x 8.38"
38	1			LAF9431	Pin .75" x 4.75"
39	2			LAF9432	Bushing 1.44" x .13" x 5.56"

**NOTE: All parts are the same as the LAF5694 except for those parts numbered under the other models.**

# PTO POWER RAKE PARTS ILLUSTRATION

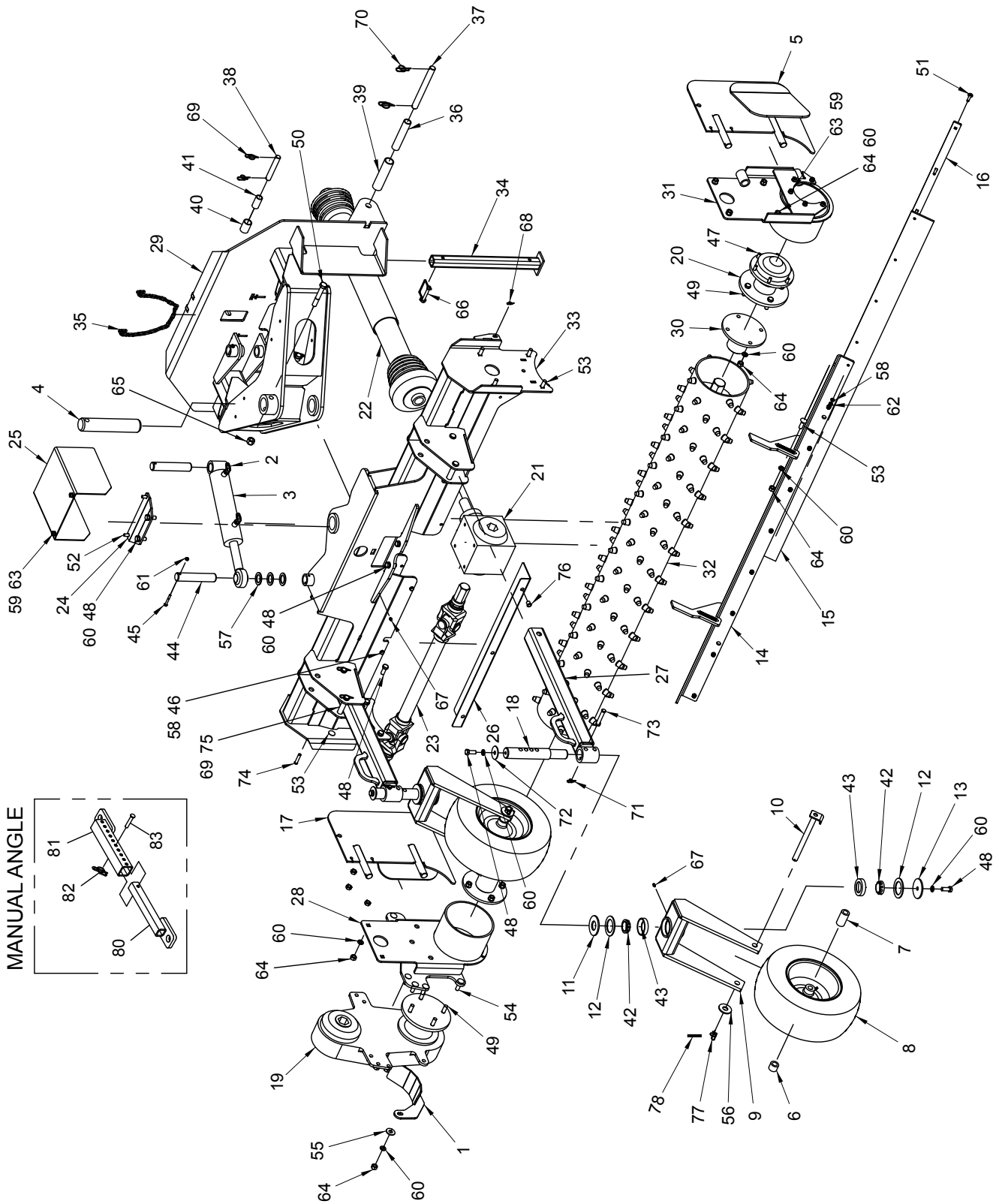

## PTO POWER RAKE PARTS LIST

ITEM	QTY.	LAF5660 56"	LAF5676 72"	LAF5694 90"	DESCRIPTION
40	1			LAF9433	Top Link Bushing
41	1			P126250	Top Link Bushing
42	4			P760500	Bearing Race
43	4			P760300	Tapered Roller Bearing Cone
44	2			LAF9715	Pin 1.25" x 6.5"
45	2			07-3022	Grade 8 Hex Head Cap Screw .25" x 2"
46	varies	(2)	(3)	(4) RHW1105	Grade 5 Hex Head Cap Screw .31" x 1"
47	5			P100605	Grade 5 Hex Head Cap Screw .38" x 1.25"
48	11			P100805	Grade 5 Hex Head Cap Screw .5" x 1.25"
49	8			RHW1406	Grade 5 Hex Head Cap Screw .5" x 1.75"
50	1			RHW1612	Grade 5 Hex Head Cap Screw .63" x 4"
51	varies	(7)	(9)	(12) P104506	Grade 5 Carriage Bolt .31" x 1.5"
52	2			RHW2205	Grade 5 Carriage Bolt .38" x 1"
53	13			RHW2405	Grade 5 Carriage Bolt .5" x 1.5"
54	2			07-3709	Grade 5 Carriage Bolt .5" x 1.75"
55	2			RHW5462	Grade 5 Flat Washer .5" USS
56	2			P850612	Grade 5 Flat Washer .75" USS
57	3			P855120	Machinery Bushing .135" x 1.25" ID
58	varies	(12)	(15)	(19) P851105	Grade 5 Lock Washer .31"
59	7			P851106	Grade 5 Lock Washer .38"
60	34			P851108	Grade 5 Lock Washer .5"
61	2			RHW7003	Grade 5 Lock Nut .5"
62	varies	(9)	(9)	(12) RHW7101	Grade 5 Hex Nut .31"
63	7			RHW7201	Grade 5 Hex Nut .38"
64	23			RHW7401	Grade 5 Hex Nut .5"
65	1			RHW7602	Grade 5 Nylock Nut .63"
66	1			RHW8079	Snapper Pin .38" x 2.75" (2.5" Usable)
67	3			07-3112	Grease Zerk .25" self-tapping (28 tpi)
68	2			RHW8114	Rue Ring Cotter Pin .38" Regular
69	6			RHW8115	Rue Ring Cotter Pin .75" Heavy
70	4			RHW8130	Rue Ring Cotter Pin .88" Heavy
71	2			RHW8133	Rue Ring Cotter Pin .5" Heavy
72	2			RHW8136	Washer .5" x 2" OD x .093" Thick
73	2			RHW8150	Clevis Pin .5" x 2.75" (2.53" Usable) Plated
74	2			RHW8225	Clevis Pin .38" x 1.75" (1.53" Usable) Plated
75	4			RHW8227	Clevis Pin .75" x 3.5" (3.25" Usable) Plated
76	varies	(2)	(3)	(4) RHW8642	Rivet Nut .31"-18 .027-.150 Grip Range
77	2			P158000	Grade 5 Hex Slotted Nut .75"-16 Plated
78	2			07-1044	Grade 2 Cotter Pin .13" x 1.5"

**NOTE: All parts are the same as the LAF5694 except for those parts numbered under the other models.**

# PTO POWER RAKE PARTS ILLUSTRATION

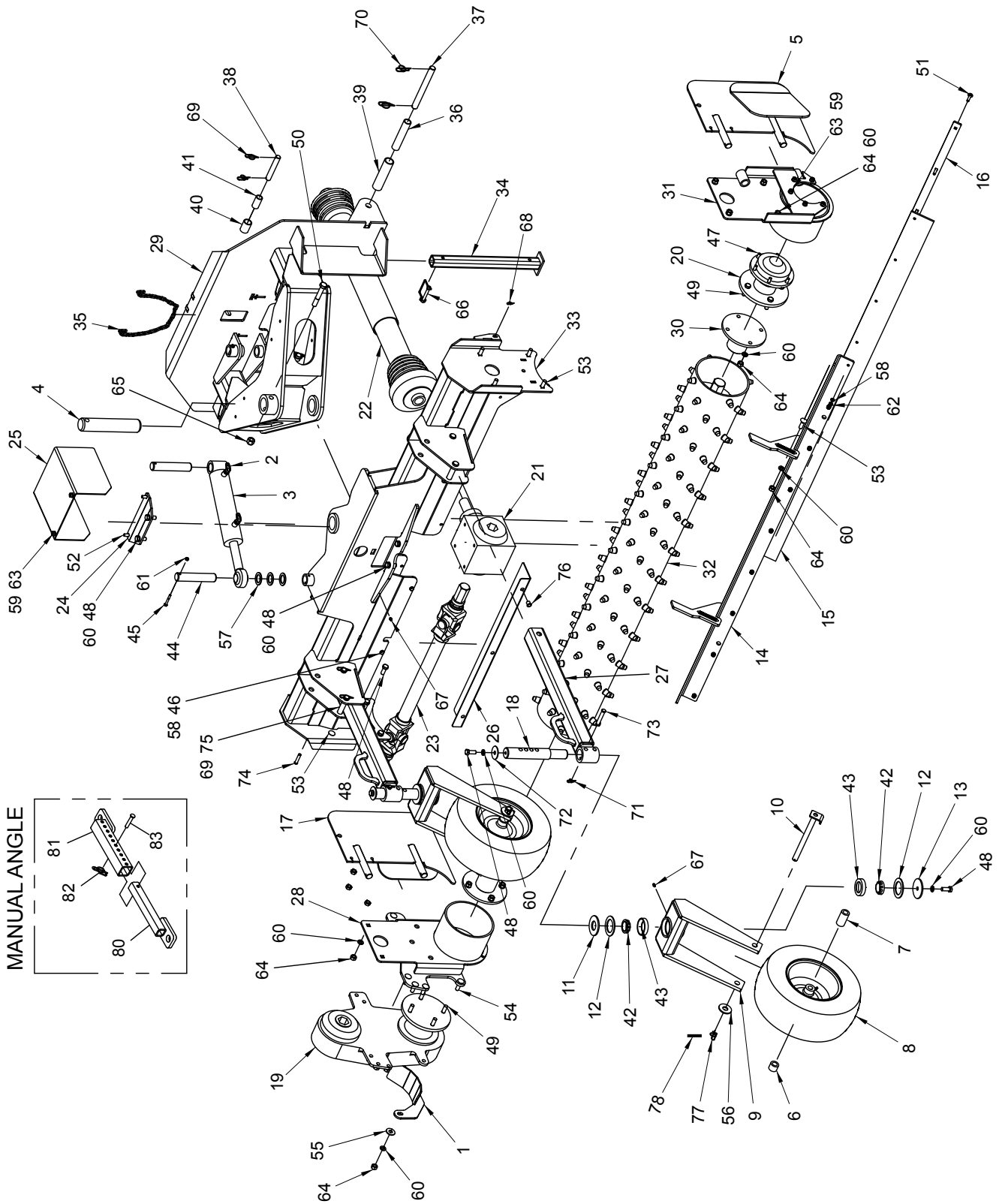

## PTO POWER RAKE PARTS LIST

**FOR MANUAL ANGLE MODELS (See list below -- which replace the cylinder.)**

ITEM	QTY.	LAF5696 56"	LAF5697 72"	LAF5698 90"	DESCRIPTION
80	1			LAF2818	Position Tube (male)
81	1			LAF2817	Position Tube (female)
82	1			RHW8133	Rue Ring Cotter Pin .5" Heavy
83	1			RHW8150	Clevis Pin .5" x 2.75" (2.53" Usable) Plated

**NOTE: All parts are the same as the LAF5698 except for those parts numbered under the other models.**

# HYDRAULIC ANGLE KITS PARTS ILLUSTRATION & LISTS

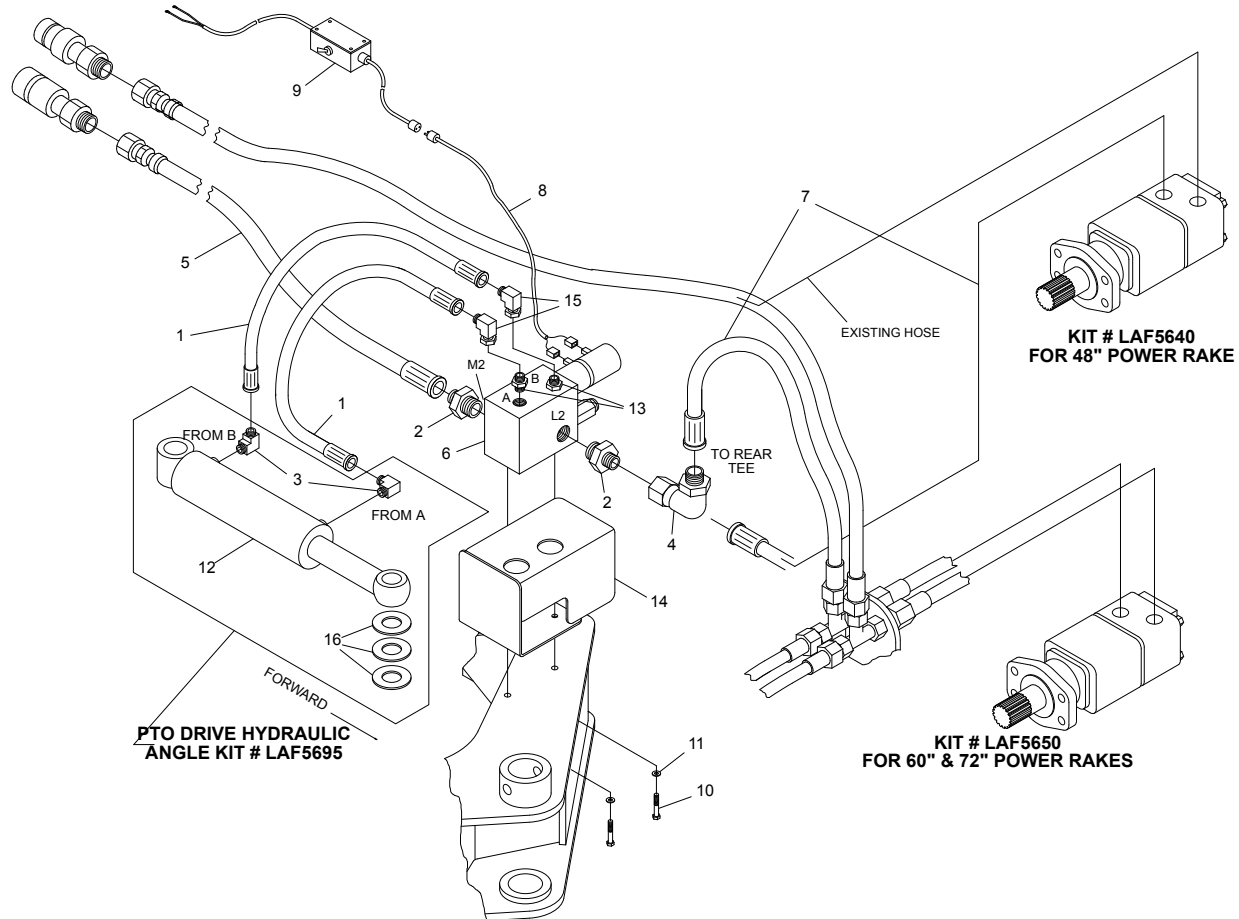

ITEM	QTY.	LAF5640 PART #	LAF5650 PART #	LAF5695 PART #	DESCRIPTION
1	2	LAF4308	LAF4308		Hydraulic Hose .38" x 19" 6FJ-6FJ
2	2	P276458	P276458		Hydraulic Adapter 10MJ-12MB
3	2	P261350	P261350	P261350	Hydraulic Elbow 90° 6MB-6MJ
4	1		LAF4417		Hydraulic Elbow 90° 10MJ-10FJ
5	1	LAF4719	LAF4658		Hydraulic Hose .5" x 72" 10FJ-10MB Hydraulic Hose .63" x 72" 10FJ-12MB
6	1	LAF4660	LAF4660		Solenoid Operated Control Block Assembly
7	1	LAF4657 (48")	LAF4681 (22")		Hydraulic Hose .5" x (length noted) 10FJ-10FJ
8	1	LAF9441	LAF9441		Wire Assembly 9'
9	Contact FFC to obtain correct				Wire Harness with Box for Rotating Cylinder
10	2	P100505	P100505		Grade 5 Hex Head Cap Screw .31" x 1.25"
11	2	P851105	P851105		Grade 5 Lock Washer .31"
12	1	LAF4516	LAF4516	LAF4516	Hydraulic Cylinder 2.5" x 7.5" x 1.25" Shaft
13	2	03-2140	03-2140		Hydraulic Adapter 6MJ-6MB
14	1	LAF5659	LAF5659		Shield
15	2	LAF4093	LAF4093		Hydraulic Elbow 90° 6FJ-6MJ
16	3	P855120	P855120	P855120	Machine Bushing



# Limited Warranty

Except for the Excluded Products as described below, all new products are warranted to be free from defects in material and/or workmanship during the Warranty Period, in accordance with and subject to the terms and conditions of this Limited Warranty.

1. Excluded Products. The following products are excluded from this Limited Warranty:

(a) Any cable, part that engages with the ground (i.e. sprockets), digging chain, bearing, teeth, tamping and/or demolition head, blade cutting edge, pilot bit, auger teeth and broom brush that either constitutes or is part of a product.

(b) Any product, merchandise or component that, in the opinion of Paladin Light Construction<sup>1</sup>, has been (i) misused; (ii) modified in any unauthorized manner; (iii) altered; (iv) damaged; (v) involved in an accident; or (vi) repaired using parts not obtained through Paladin Light Construction.

2. Warranty Period. The Limited Warranty is provided only to those defects that occur during the Warranty Period, which is the period that begins on the first to occur of: (i) the date of initial purchase by an end-user, (ii) the date the product is first leased or rented, or (iii) the date that is six (6) months after the date of shipment by Paladin Light Construction as evidenced by the invoiced shipment date (the "Commencement Date") and ends on the date that is twelve (12) months after the Commencement Date.

3. Terms and Conditions of Limited Warranty. The following terms and conditions apply to the Limited Warranty hereby provided:

(a) Option to Repair or Replace. Paladin Light Construction shall have the option to repair or replace the product.

(b) Timely Repair and Notice. In order to obtain the Limited Warranty, (i) the product must be repaired within thirty (30) days from the date of failure, and (ii) a claim under the warranty must be submitted to Paladin Light Construction in writing within thirty (30) days from the date of repair.

(c) Return of Defective Part or Product. If requested by Paladin Light Construction, the alleged defective part or product shall be shipped to Paladin Light Construction at its manufacturing facility or other location specified by Paladin Light Construction, with freight PRE-PAID by the claimant, to allow Paladin Light Construction to inspect the part or product.

Claims that fail to comply with any of the above terms and conditions shall be denied.

## **LIMITATIONS AND EXCLUSIONS.**

**THIS LIMITED WARRANTY IS IN LIEU OF ALL OTHER WARRANTIES, EXPRESS OR IMPLIED, INCLUDING WITHOUT LIMITATION THE WARRANTIES OF MERCHANTABILITY, FITNESS FOR A PARTICULAR PURPOSE AND ANY WARRANTY BASED ON A COURSE OF DEALING OR USAGE OF TRADE.**

**IN NO EVENT SHALL PALADIN LIGHT CONSTRUCTION BE LIABLE FOR CONSEQUENTIAL OR SPECIAL DAMAGES.**

**IN NO EVENT SHALL PALADIN LIGHT CONSTRUCTION BE LIABLE FOR ANY LOSS OR CLAIM IN AN AMOUNT IN EXCESS OF THE PURCHASE PRICE, OR, AT THE OPTION OF PALADIN LIGHT CONSTRUCTION, THE REPAIR OR REPLACEMENT, OF THE PARTICULAR PRODUCT ON WHICH ANY CLAIM OF LOSS OR DAMAGE IS BASED. THIS LIMITATION OF LIABILITY APPLIES IRRESPECTIVE OF WHETHER THE CLAIM IS BASED ON BREACH OF CONTRACT, BREACH OF WARRANTY, NEGLIGENCE OR OTHER CAUSE AND WHETHER THE ALLEGED DEFECT IS DISCOVERABLE OR LATENT.**

<sup>1</sup>Attachment Technologies Inc., a subsidiary of Paladin Brands Holding, Inc. (PBHI) is referred to herein as Paladin Light Construction.

February 10, 2010

